

**PHILIPS**

Lighting Control

Wireless Occupancy  
Sensor, Wireless Multi  
Sensor



---

# Technical Application Guide

Easily enhance your smart lighting system with the Philips wireless occupancy sensor and multi sensor, which are Interact Ready. They trigger automatic responses to turn on, off or dim the lights according to occupancy detection and daylight variation. The 2.4GHz mesh networking technology offers reliable and secure communication within the space and further towards the Interact IoT platform. The result? Greater energy saving, more control possibilities and a more adaptable space!

**interact**  
ready.

## Product Features

### Occupancy Detection

- Passive Infrared (PIR) technology to accurately detect occupancy/vacancy.
- Proprietary algorithm minimizes false trigger.
- Three-level adjustable sensitivity setting.

### Daylight Sensing <sup>[1]</sup>

- High accuracy of ambient light measurement from 1-2000 LUX
- Closed loop daylight regulation
- Daylight fast report for calibration

### Installation

- Battery-powered, no mains wire required.
- Quick and easy mounting with tapes or screws.
- Walk test mode available for optimal detection.
- Indoor use only.

### Environment

- No Mercury.
- Low Carbon Footprint.

### Connectivity

- 2.4GHz mesh networking technology.
- Reliable and secure wireless communication, nominal range 15m (49ft).
- Easy commissioning.

### Control Functionality

- Automatic light control based on occupancy detection and daylight sensing<sup>[1]</sup>.
- Adjustable sensor parameters for personalized lighting behaviors.

### Reliability

- Reliable operation between -5°C and +45°C ambient temperature.
- Battery lifetime above 8 years. Minimum maintenance. <sup>[2]</sup>
- IP42 (IEC standard 60529)

[1]: For multi sensor only.

[2]: As calculated in typical conference room application.

## Application



Retail



Industry

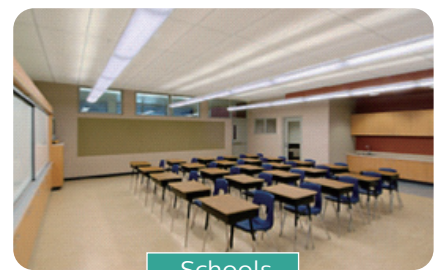

Schools

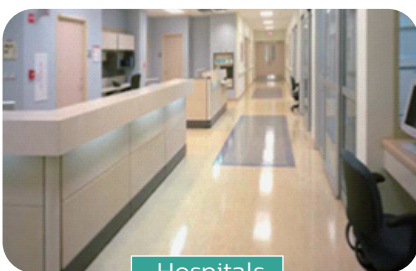

Hospitals

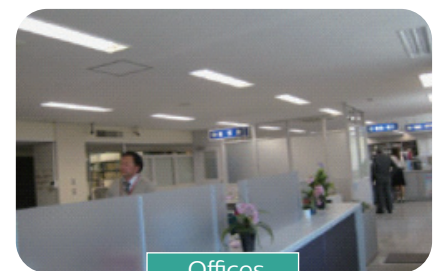

Offices

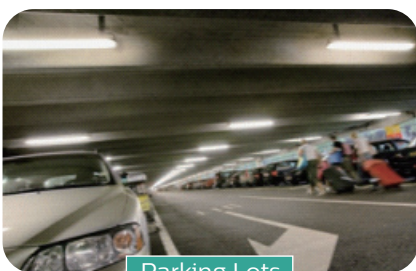

Parking Lots



Warehouses

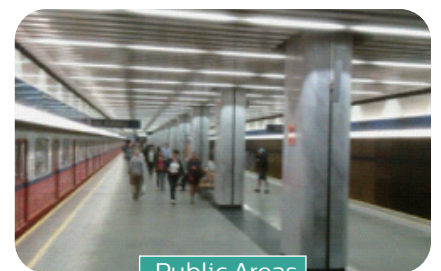

Public Areas

## Field-of-View

- Field-of-view (FOV) for motion detection is determined at typical height ( $h=2.5\text{m}$ ) for major and minor motion with NEMA tests, respectively. Daylight FOV is for multi sensor only.

### Motion FOV

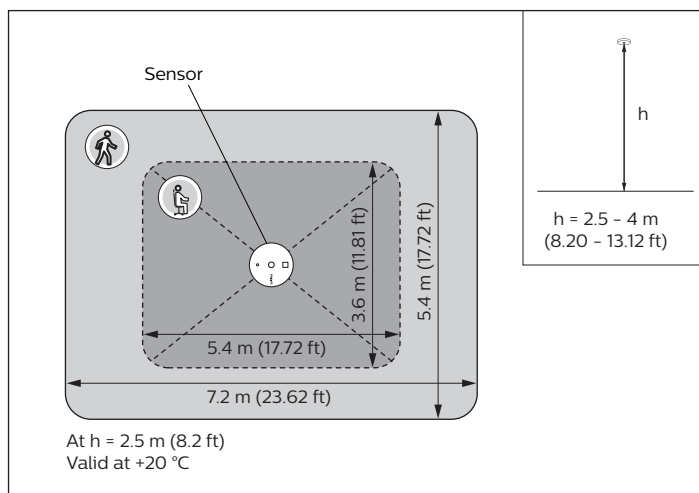

### Daylight FOV

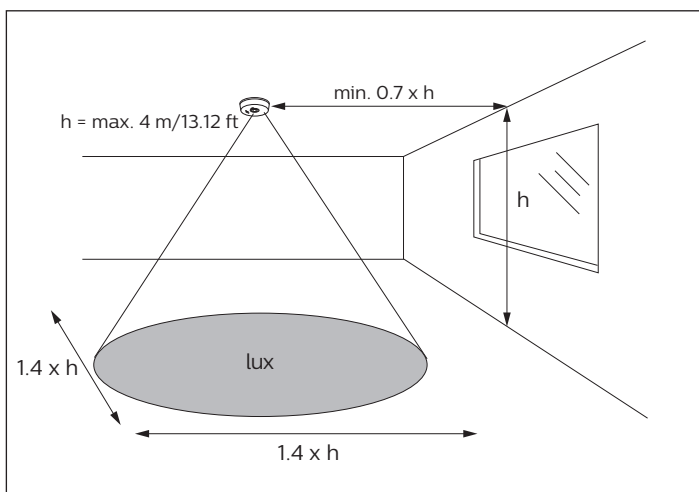

- Motion FOV can be reduced using the plastic shield around the lens.

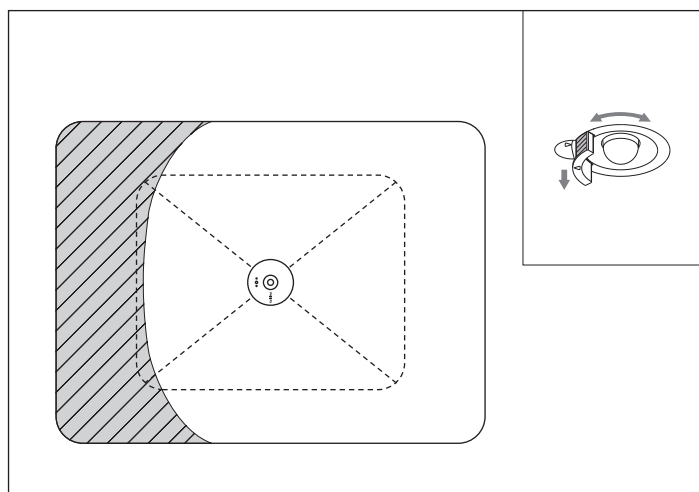

# Installation Instructions

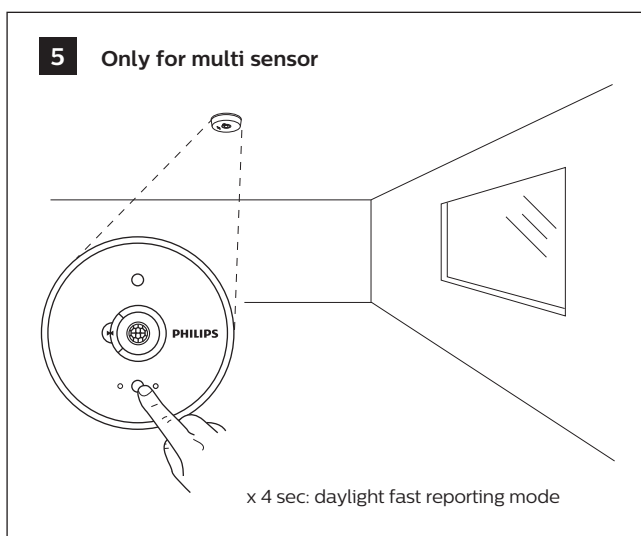
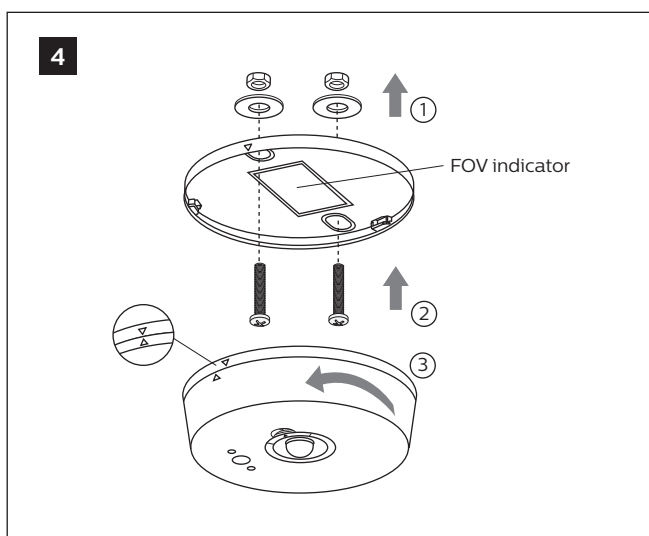
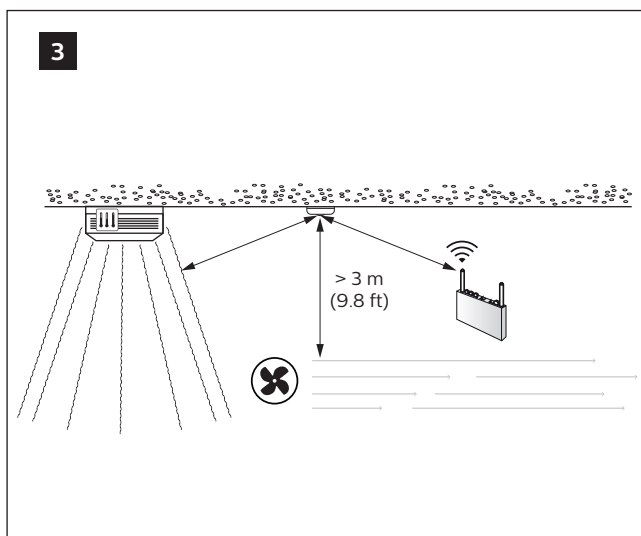
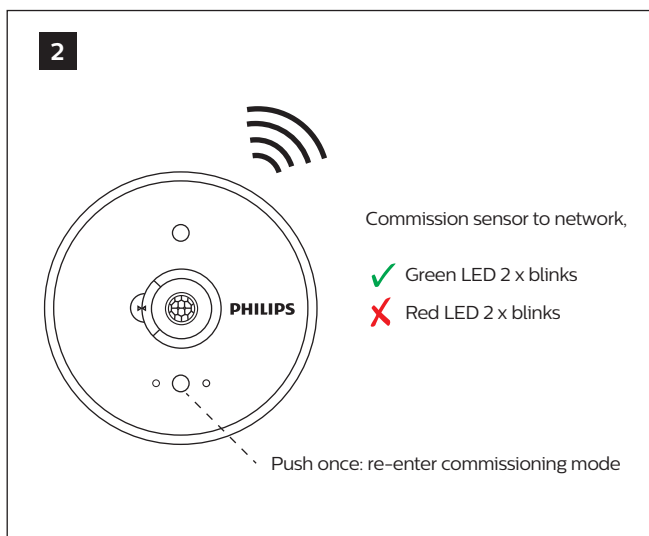
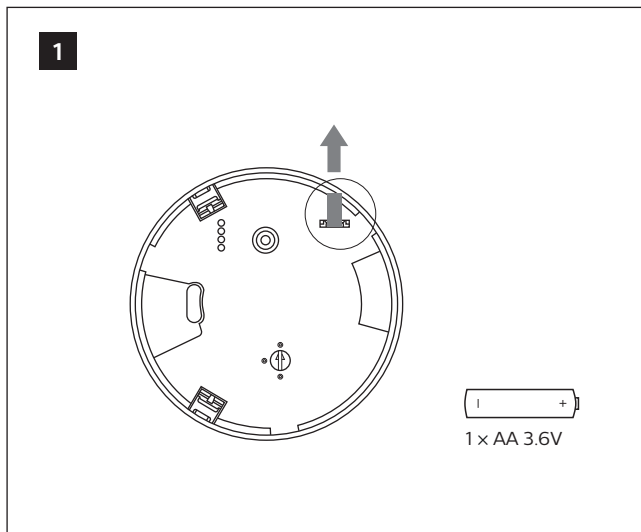
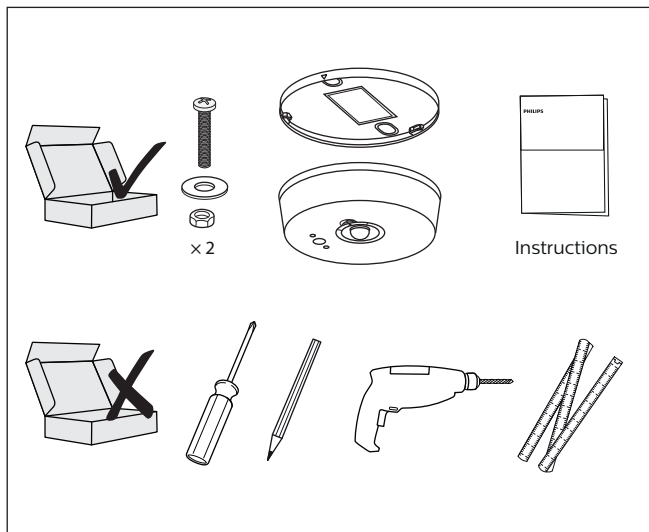

- A walk test will help to determine the optimal location to place the sensor by quickly testing the occupancy detection coverage. It's ONLY possible after sensor has been commissioned.

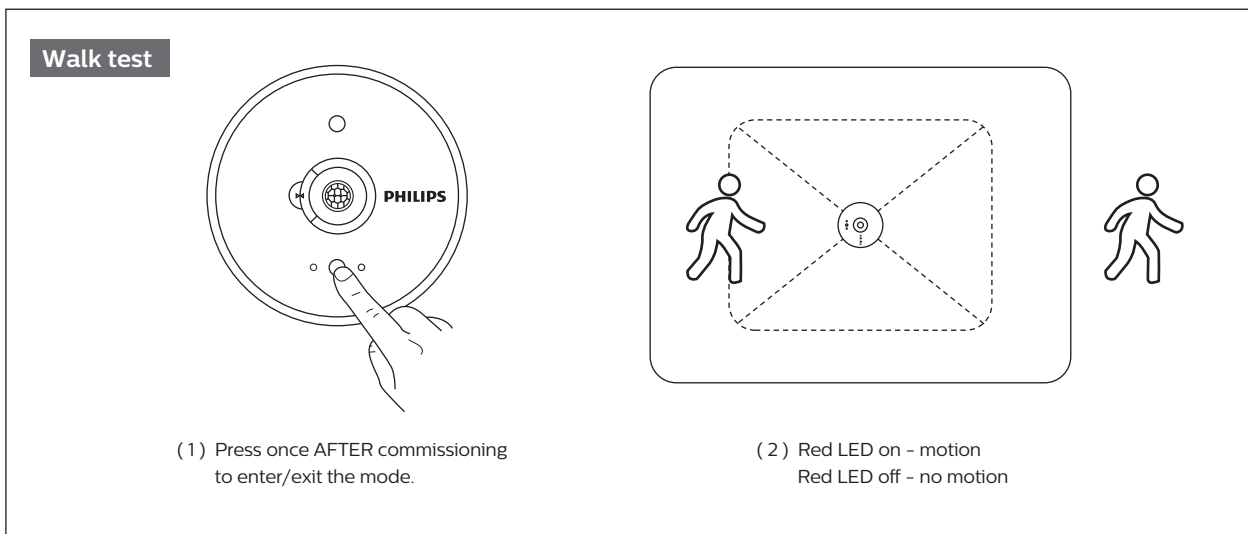

- If needed, the sensitivity for motion detection can be adjusted with the dial at the back. Three sensitivity levels are available from Low, Medium to High (High as default).

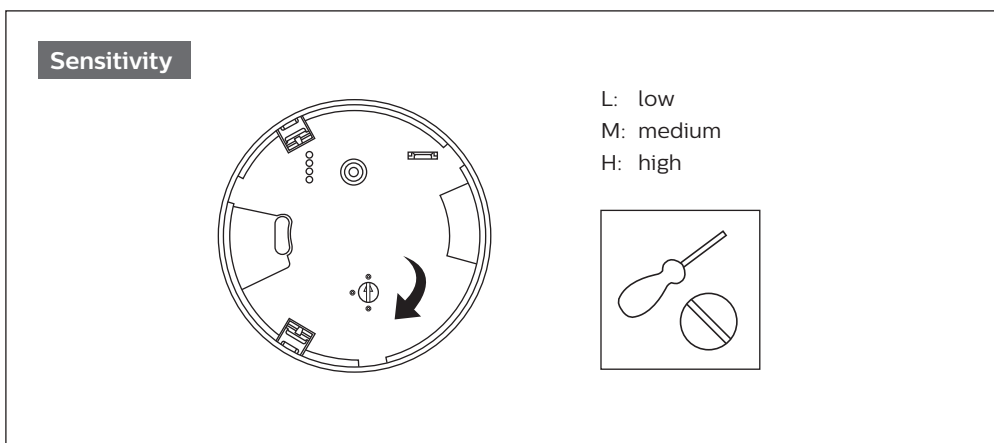

- Performing factory reset will restore sensor to un-commissioned status. Sensor will be removed from current network (if any).

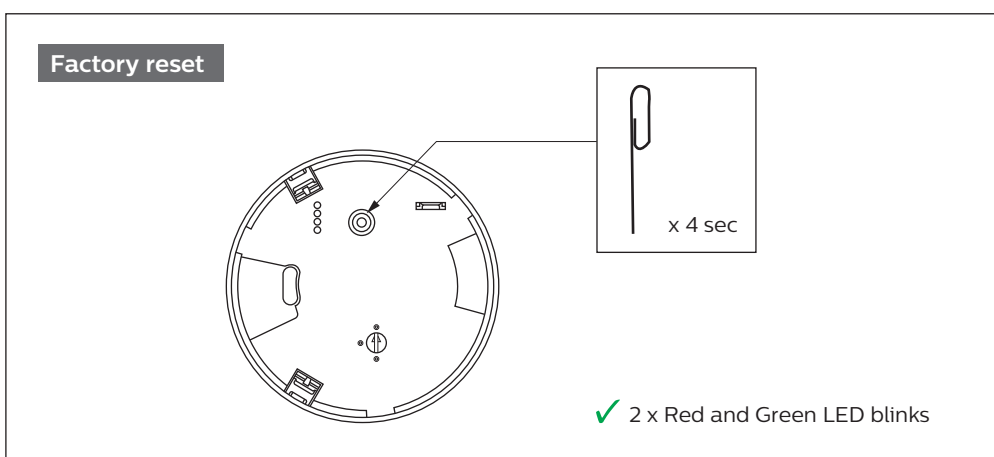

## LED indicator

LED pattern	
Green LED blinks every 10s	Ready for commissioning
Green LED blinks every 2s	Commissioning in progress
Green LED flash × 2	Commissioning successful
Red LED flash × 2	Commissioning failure
Green and Red LEDs flash × 2	Successful factory reset
Red LED flash × 1	Motion detected in walk test mode
Green LED flash × 6	Occupancy detected
Red LED flash × 3	Occupancy detected and battery low

## Dimensions

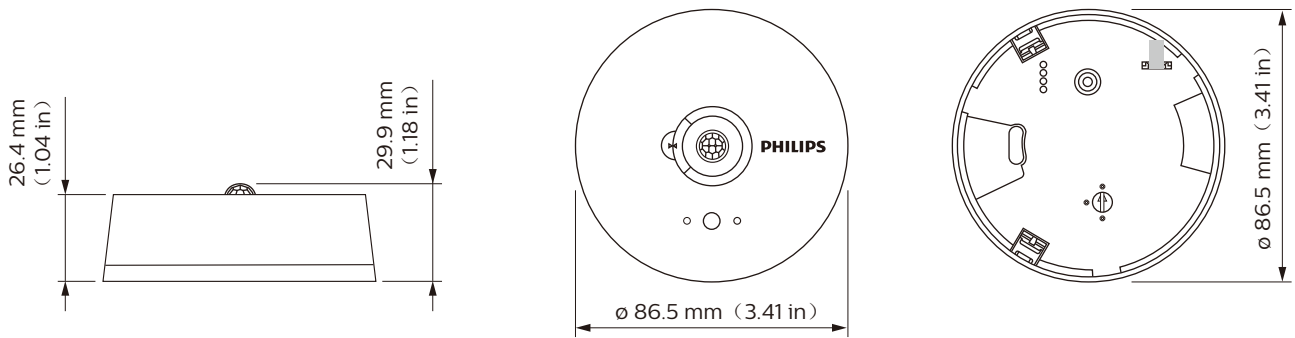

## Temperature

Operating temperature	T <sub>operating</sub>	min -5°C	max +45°C
Storage temperature	T <sub>storage</sub>	min -25°C	max +65°C

## Technical Specs and Order Information

Product number	Product Description	Type	Mounting height	Motion FOV at h=2.5m	Battery lifetime	RF range open-air	Daylight level
			( m )	( sqm )	( yr )	( m )	( lux )
9290018190	OCC SENSOR IA CM WH	Occupancy, ceiling mounted	≤4	5.4 x 7.2 (major) 3.6 x 5.4 (minor)	>8	15	--
9290018191	OCC-DL SENSOR IA CM WH	Occupancy and daylight, ceiling mounted	≤4	5.4 x 7.2 (major) 3.6 x 5.4 (minor)	>8	15	1-2000

## Approbation & Certificates

Philips wireless occupancy sensor and multi sensor follow applicable legislation and standard. The product complies with **UL**, **cUL** and **CE**.



## Application Notes

- Product is battery operated. Use only the specified battery type (3.6V AA). Misuse of battery may cause risk of fire or damage the device.
- Designed for indoor use only. DO NOT use in applications with high levels of condensation.
- Reliable operation between -5 °C to +45 °C ambient temperature.
- Modifications to the product void the limited warranty. For warranty information, please see [www.lighting.philips.com](http://www.lighting.philips.com).
- You are required to read and understand the Quick Installation Guide and all warnings, cautions and other materials related to installation before commencing installation work.



© 2018 Philips Lighting

All rights reserved. Reproduction in whole or in part is prohibited without the prior written consent of the copyright owner. The information presented in this document does not form part of any quotation or contract, is believed to be accurate and reliable and may be changed without notice. No liability will be accepted by the publisher for any consequence of its use. Publication thereof does not convey nor imply any license under patent or other industrial or intellectual property rights.

05/2018  
[www.philips.com](http://www.philips.com)