

EMERGENCY EXIT LIGHTS

FINESCO



KL/M/W510RM (E) C/W HS



KL/M/W5100 C/W HS

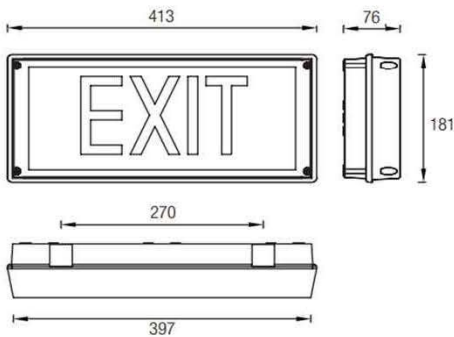

Dimension: mm NTS
High Tech L.E.D
from **NICHIA** (made in Japan)



Surface/Semi-recessed Mount
Weatherproof Exit Sign



IP65
CLASS 1

SMT LED with lifespan 50,000 burning hours

Indoor, outdoor, corrosion resistant weatherproof emergency exit light

TECHNICAL DATA

Mode of operation	: Maintained
Lamp	: Maxspid 1W T2 SMT LED Lamp
Rated duration	: 2 hr and others
Mains supply	: 230 Volts, 50/60Hz
Power consumption	: 2VA
Battery	: Nickel-metal hydride
Charge monitor	: Green LED Ø5mm
Test facility	: Push-off test switch
Safety feature	: Low volt cut-off preventing battery overdischarge
Housing & Diffuser	: Injection moulded fire retardant, high impact polycarbonate
Mounting	Wall, ceiling suspended or semi-recessed
Cable entry	Ø20mm K/O hole
Weight	: 1.7kg (gross)
Compliance	: SS563:Part 1 & 2, SS263:Part 2
Warranty	: 1 year

ORDERING GUIDE

(Please check with Sales Dept if customisation is required)

Single Sided	Legend
KL/M/W5100	
KL/M/W5100 (R)	
KL/M/W5100 (L)	
KL/M/W510RM	
KL/M/W510RM (E)	
KL/M/W510RM (W)	

Note:

The above c/w heating strip and thermostart for cold room application - 30Deg

KEY FEATURES

- > using surface mount technology LED
- > high durability & reliability
- > low heat
- > low power consumption
- > low maintenance
- > no "black ends"
- > snap-on T2 SMT LED lamp for easy replacement

Specifications subject of changes without prior notice