



Model: SLE-WP

WEATHER PROOF EMERGENCY FLOOD LIGHT

SPECIFICATION:

Input Voltage:	220V+/-10%, 50 / 60Hz
Mode of Operation:	Non-maintained
Lamp:	2 X 22W SMD LED / 2 X 3W Hi-Power LED
Rated Duration:	2 or 3 hours
Power Consumption:	5.9VA
Battery Type:	Ni-Cd / SLA
Safety Feature:	Over discharge and overcharge protection
Test Facility:	Micro switch for independent test
Compliance:	MS 619, IEC 598-2-22
IP:	54 / 65
Warranty:	1 year

Benefits:

- Water Proof*
- High Durability*
- Easy Installation*
- AC / DC Operated*
- Maintenance Free*
- Power saving 80%*

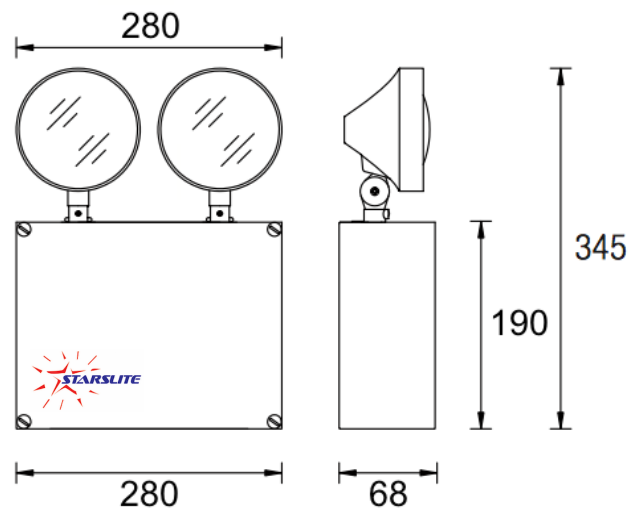

ENVIRONMENTALLY FRIENDLY

Dimension: mm NTS



Note: Due to continuous development and improvement, our company reserve the right to change specification without notice